

Rely on UNIFI's expert team to rapidly and effectively create your BIM content – on demand.

UNIFI has been creating high quality BIM content for organizations across the globe for years. Our customers tell us they used to struggle with meeting their unpredictable and varied content creation needs, as it took their designers' valuable time away from designing actual buildings and projects. To alleviate that challenge, they leverage the expertise of our world-class team of content creators as an extension of their own team. Here are the ways that our content creation team can support your content needs:

#### CONTENT CREATION – Flexible options to meet your needs On-demand

- Extension of your in-house designers/content creation team.
- UNIFI serves as your overflow partner, delivering content on-demand as needed.
- Reserved space in our factory in place of hiring an additional resource or going out and engaging with a new content creation team every time you need support.

#### Specific Project

- Ideal for one-off content project that doesn't require a rapid turnaround, i.e. a library upgrade or large number of content families.
- Convenience and knowledge that any content from UNIFI team is of the highest quality.
- Lower cost per credit than on-demand pricing where we are reserving capacity for your team.

**Content Analysis** – Leverage our team's expertise coupled with UNIFI's Content Analysis tool to assess the health of your library and receive quarterly reports on an ongoing basis

#### Content Credits – How it works.

A Content Credit is a unit of content creation time that can be applied to requesting any type of content your organization needs created. Content credits can be purchased in project-specific buckets or individually, and can be used for your content needs throughout the quarter. Our customers tell us Content Credits make it easy for them to budget for their content creation needs and rely on our team's expertise and speed when they don't have the time or in-house experience to create the content their projects require.

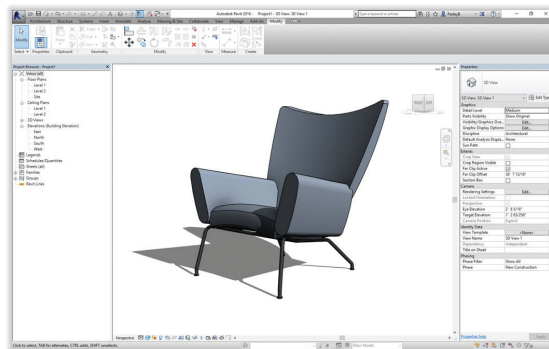
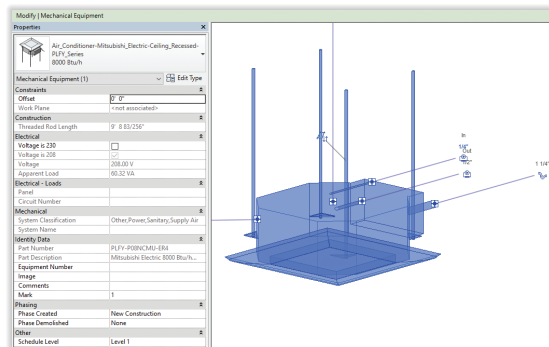

*“With UNIFI, we have a way to contain content as a single point of truth.”*

## Content Credits – Frequently Asked Questions.

### 1. How do I track and approve which content requests from my team are appropriate?

Our team works with your BIM Manager or Revit Leader to determine the appropriate approval process for submitting a content request after the purchase of any credit package, so that we are able to determine how your organization would like to approve – or not approve – any requests submitted by your designers.

### 2. Will you alert me if I’m running low on credits?

Of course! Our Content Creation Customer Success Managers keep a careful eye on your credit reserve and will notify you as soon as you reach 20 credits so that you have time to top up before hitting zero.

### 3. How do I know what my credits were used for?

Our Content Creation Customer Success Managers deliver a monthly report that provides a summary of all requests made over the last 30 days, along with a calculation of how many credits you have remaining in your account.

### 4. Do credits expire?

Yes, content credits are valid for a set amount of time depending on what type of credit you are using, after which point they expire. Your expiration date is highlighted on your monthly usage report, and a burndown graph visualizing your expected usage vs. actual usage is provided in that report as well, enabling you to recognize any under- or over-usage so that you can adjust your usage appropriately.

### 5. What will a credit get me?

Based on our extensive experience creating content and tracking the effort required by our Content Creation Team to create, test and deliver BIM content of the highest standards, we have established the guidelines below, which provide an estimate of how many credits are required to produce a specific type of content. Please note that these estimates are suggestions, as each component is unique and may require more or less credits than the averages provided below:

#### Content Credits Estimated by Family Category

Family	Credit Pull	Family	Credit Pull
Air Terminals	4	Furniture	4
Cable Tray Fittings	6	Furniture Systems	8
Cable Trays	6	Generic Models	4
Casework	4	Lighting Devices	4
Ceilings	6	Lighting Fixtures	6
Columns	2	Mass	8
Communication Devices	3	Mechanical Equipment	8
Conduit Fittings	6	Nurse Call Devices	3
Conduit Runs	6	Parking	3
Conduits	6	Pipe Accessories	5
Curtain Panels	4	Pipe Fittings	6
Curtain Systems	9	Pipes	8
Curtain Wall Mullions	1	Plumbing Fixtures	5
Data Devices	3	Railings	8
Doors	7	Ramps	5
Duct Accessories	5	Roofs	7
Duct Fittings	5	Specialty Equipment	8
Duct Systems	8	Sprinklers	3
Electrical Equipment	8	Stairs	8
Electrical Fixtures	6	Telephone Devices	4
Fire Alarm Devices	4	Walls	4
Floors	5	Windows	6



#### THE SINGLE SOURCE FOR YOUR DIGITAL CONTENT NEEDS:



**UNIFI Content Management**

Source control your BIM content to ensure everyone is working on the same page – anywhere, anytime.



**UNIFI Connect**

Unites high quality manufacturer BIM content with AECO libraries and models to consolidate content needs.



**UNIFI Create**

Content creation experts who act as an extension of your team to rapidly build content to fit your specific needs.



**UNIFI Insights**

Gain actionable insights and make informed decisions to get the most from your investment in BIM content.

To learn more, please visit [www.unifilabs.com](http://www.unifilabs.com) or contact us at **702.527.6460**